

## Physical and Environmental Information

### Dimensions and Service Clearance

The printer dimensions and recommended service clearances as indicated below. With the stacker door completely open, the side dimension is reduced by 101.6 mm (4 in.). This allows for movement of the printer through smaller doorways and narrow halls.

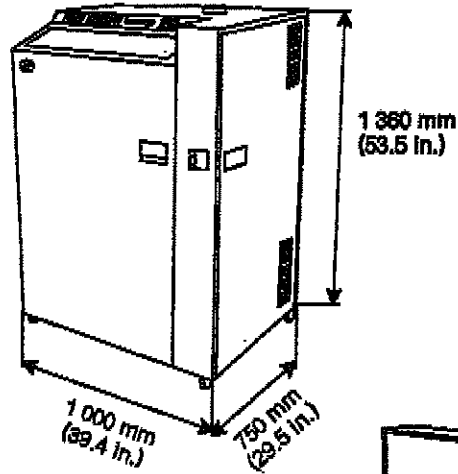

*Note: The printer needs a 760-mm (30-in.) service clearance on all sides.*

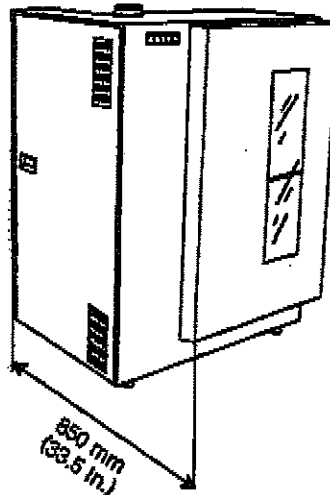

### Weight

301 kg (665 lb)

---

## List of Features

### Printing Features

- Superior print quality compared to 3262 printers
- Prints on multiple-part continuous forms up to six parts
- Prints on first line of forms, which eliminates the need for form leaders
- First line viewing feature, if selected, allows the operator to see the printed line without having to open the front unit
- Print speed of 1400 lines per minute
- 132 print positions
- Horizontal spacing of 10 characters per inch
- Vertical spacing of 6 or 8 lines per inch
- Polyester ribbon for superior print quality
- Optical Character Recognition (OCR) printing capability.

### Forms Features

- Four tractors for moving forms
- Maximum form width of 450 mm (17.72 in.)
- Maximum form width of 456 mm (17.95 in.) after Serial No. 51005 for Model 12 and Serial No. 10637 for Model 14
- Maximum form length of 356 mm (14 in.)
- Horizontal position and tension adjustment of forms done using a single knob
- End-of-forms detection
- Power forms stacker.
- Stacker Jam Detection
- Stacking Assist Option to improve forms restacking.

### Usability Features

- Easy-to-use operator panel on the front of the machine with a message display that provides prompts and status messages for the operator in native languages
- Easy-to-use operator panel on the back of the machine to operate the power stacker and start the printer
- Front unit pivots open and makes replacing forms, ribbons, and print bands easier
- Interchangeable print bands to meet a large variety of printing needs
- Automatic loading of print band information into printer's internal memory and a function that allows the operator to print the band characters within a hex code table.
- Line counting capability that helps identify when to replace supplies
- Operator-selectable automatic flight-time adjustment of print hammers so optimum print quality can be maintained
- Attention light that flashes to alert the operator when a problem exists
- Simple error recovery procedures so operator can solve most printer problems without having to call for service
- Documentation package designed to rapidly orient the user to the operation of the printer so useful printing can be done almost immediately after installation
- Slide-out stacker tray.